

## • 高温高压电动焊接闸阀

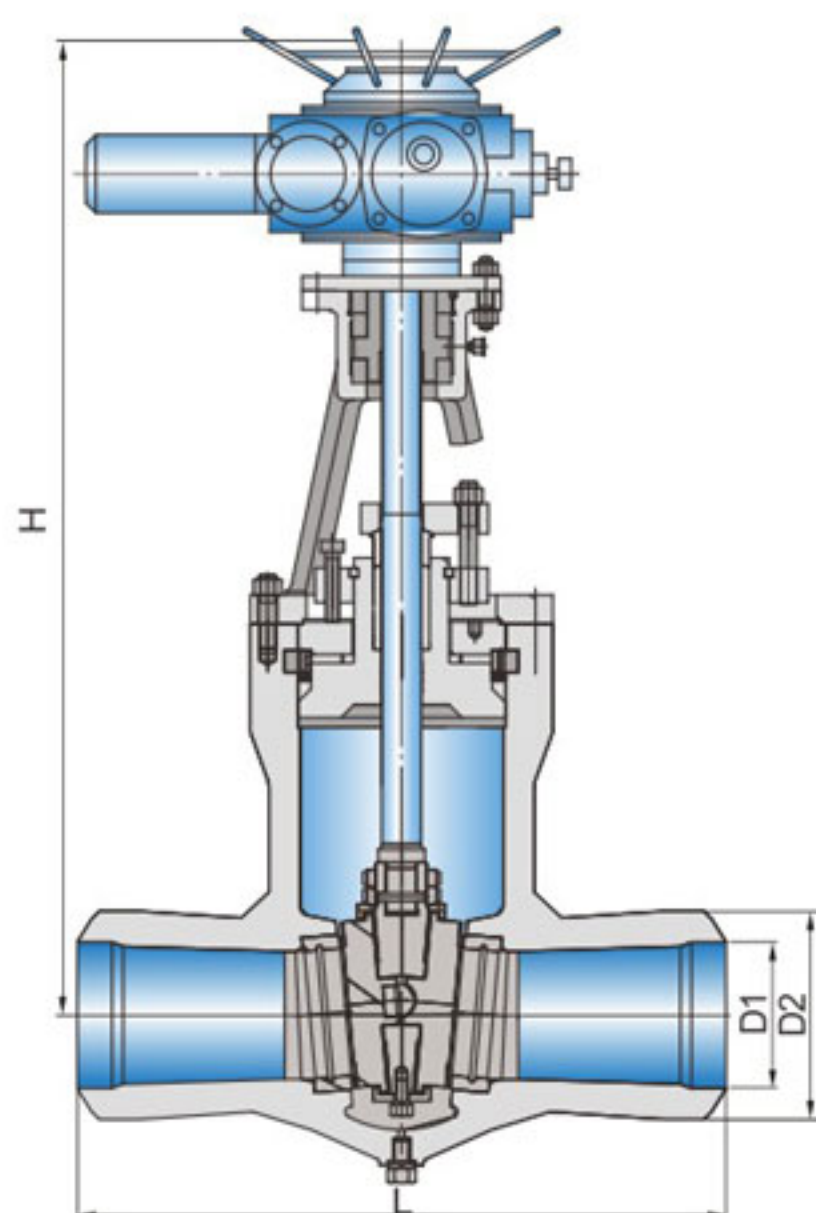

### 制造验收技术标准

1. 制造与验收技术条件按E101和JB/T 3595-2002的规定。
2. 阀门试验按JB/T 3595-2002和JB2640-81的规定阀门密封试验和上密封试验压力按JB/T 3595-2002的规定。
3. 结构长度按E101的规定或用户提供尺寸。
4. 焊接坡口按电力工业管理标准78DG的规定或按用户提供尺寸。

### Manufacture and acceptance standard

1. Manufacturing and acceptance technology conform to E101 and JB/T3595-2002.
2. Valve tests conform to JB/T3595-2002 and JB2640-81.and valve sealing tests as well as upper sealing testing pressure conform to JB/T3595-2002.
3. Structure and length conform to E101 or as specified by customer.
4. Welding slope conforms to the Power Industrial Administration Standards 78DG or as specified by customer.

### 主要外形尺寸和连接尺寸 Main Dimensions And Connection Dimensions

型号 Model	公称通径DN(mm)	L	D1	D2
Z962H-200 Z960Y-200 Z962Y-P54100V Z960Y-P54100V	150	650	164	200
	175	750	186	223
	200	750	200	262
	225	780/850	233	282
	250	950	275	325
	300	1050	312	380
	350	1150	366	430
	400	1200	410	470
	500	1400	500	570
	600	1550	580	640
Z960Y-320 Z960Y-P57170V	150	650	150	200
	175	750	170	225
	200	750	200	262
	225	780/850	207	283
	250	950	250	325
	300	1050	265	377
	350	1150	366	430
	400	1200	410	470
	500	1400	500	570
	600	1550	580	640
Z962H-250 Z960Y-250 Z962Y-P54140V Z960Y-P54140V	150	650	150	200
	175	750	176	223
	200	750	200	262
	225	780/850	220	282
	250	950	265	325
	300	1050	305	380
	350	1150	366	430
	400	1200	410	470
	500	1400	500	570
	600	1550	580	640